

DASH REFRESH (SOFT RESET)

1. Use this to refresh your interface and clear any temporary display flags.

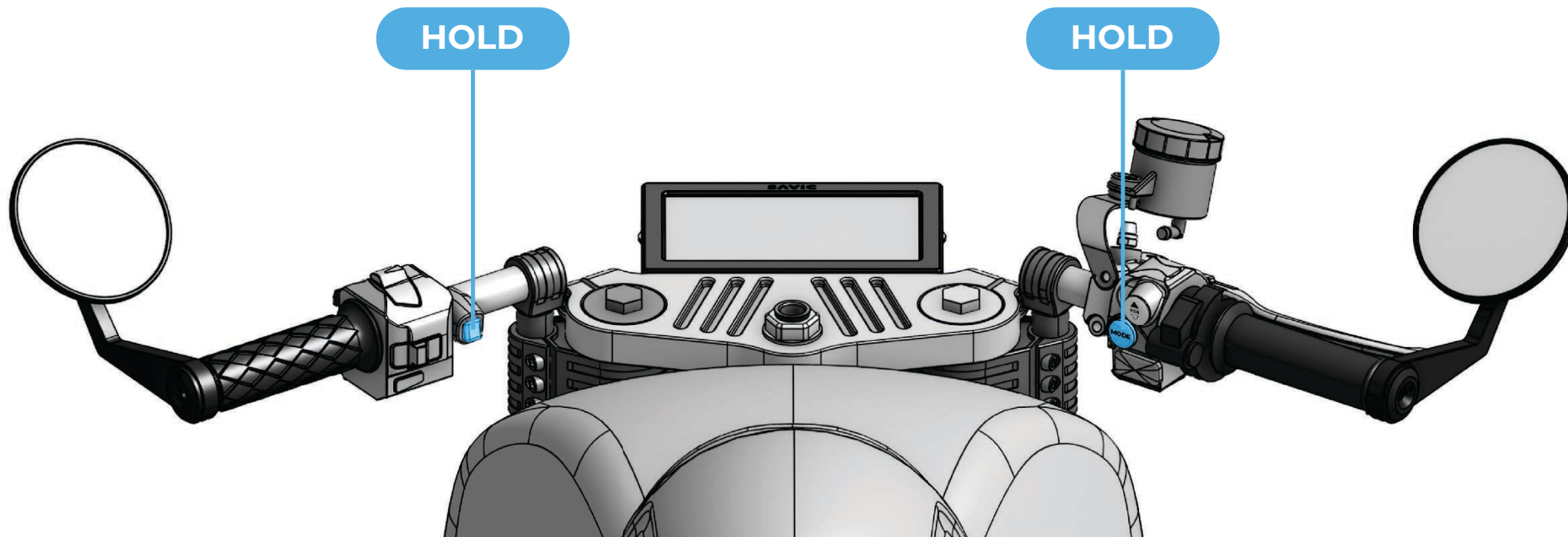

2. The dash will shut down, expect to wait a few moments for the dash to reboot. During the reboot, the dash may display grey / dark grey screen with no UI during the reboot. Wait up to 1 minute until the keypad displays.

ISOLATING MAIN BATTERY (FULL RESTART)

1. Turn the vehicle off by holding Cruise & Direction buttons until dash powers off.

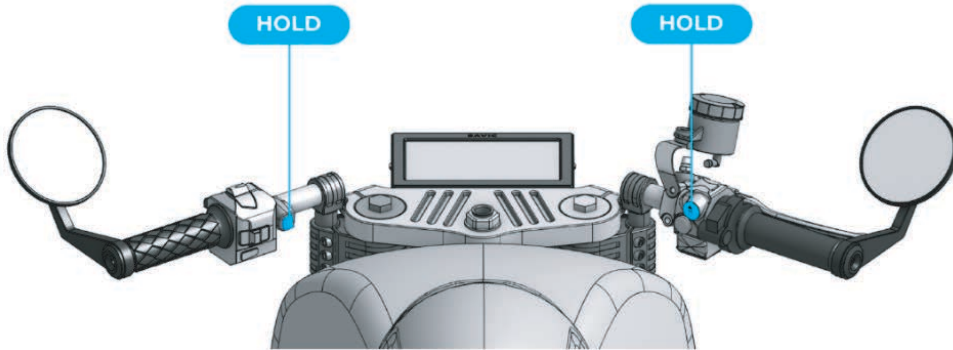

2. Disconnect 12v Battery connectors - Located under the Right Hand side of the PT Cover.

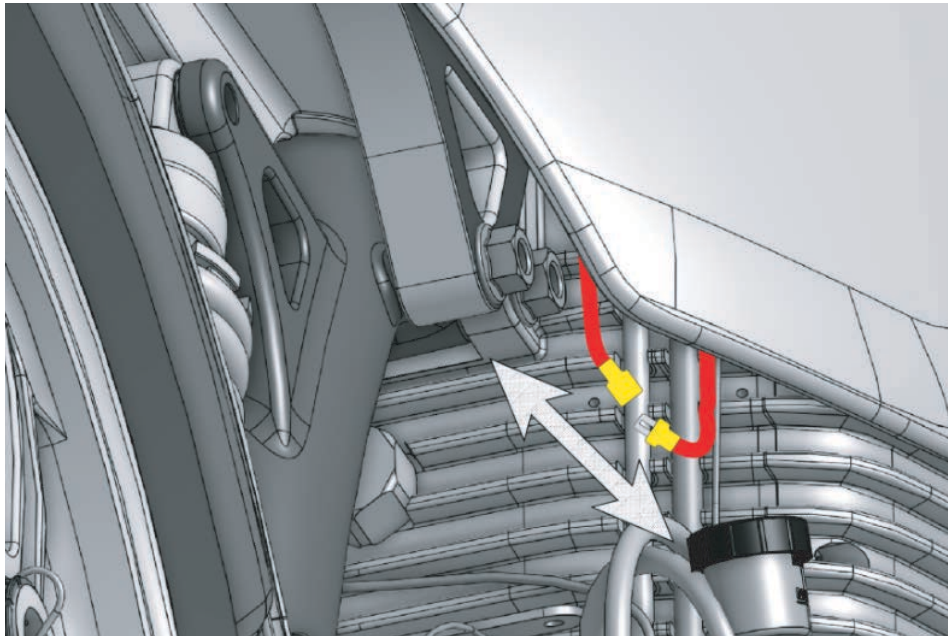

3. Toggle the LEFT indicator.

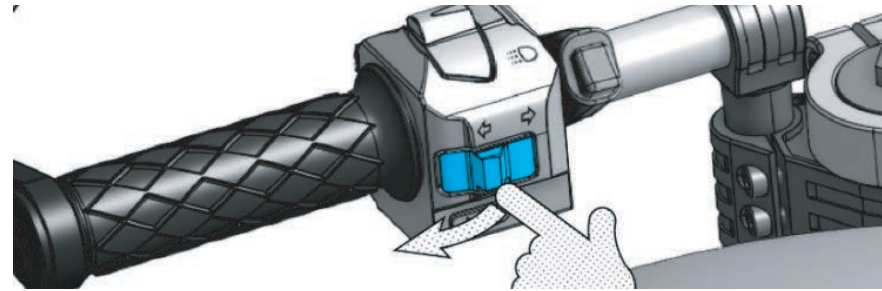

4. Hold the following buttons for 10 seconds: **Cruise, Mode, Direction, Front brake, Rear brake.**
This configuration will Isolate the motorcycle.

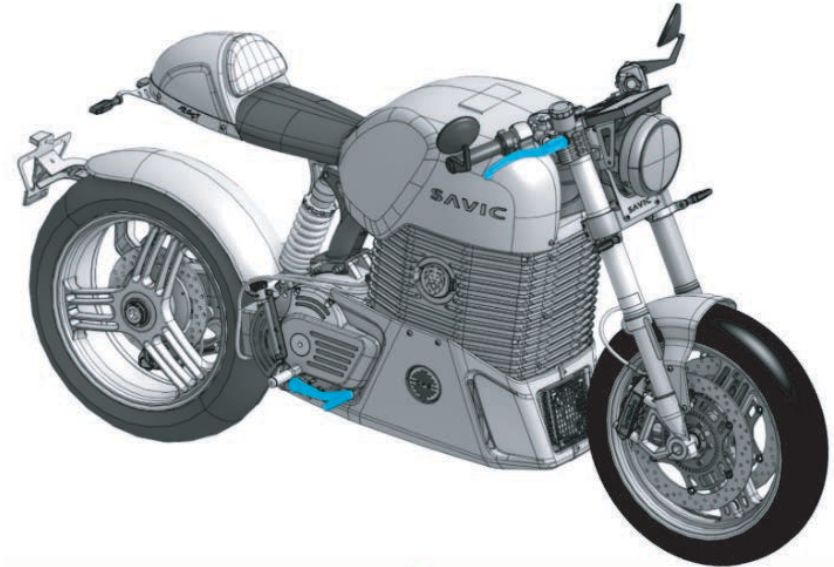

DE-ISOLATING MAIN BATTERY (REBOOT)

5. The vehicle will be completely powered down and unable to power up pressing the **MODE** button. Connect 12v Battery connectors - Located under the Right Hand side of the PT Cover. And the dash will turn on.

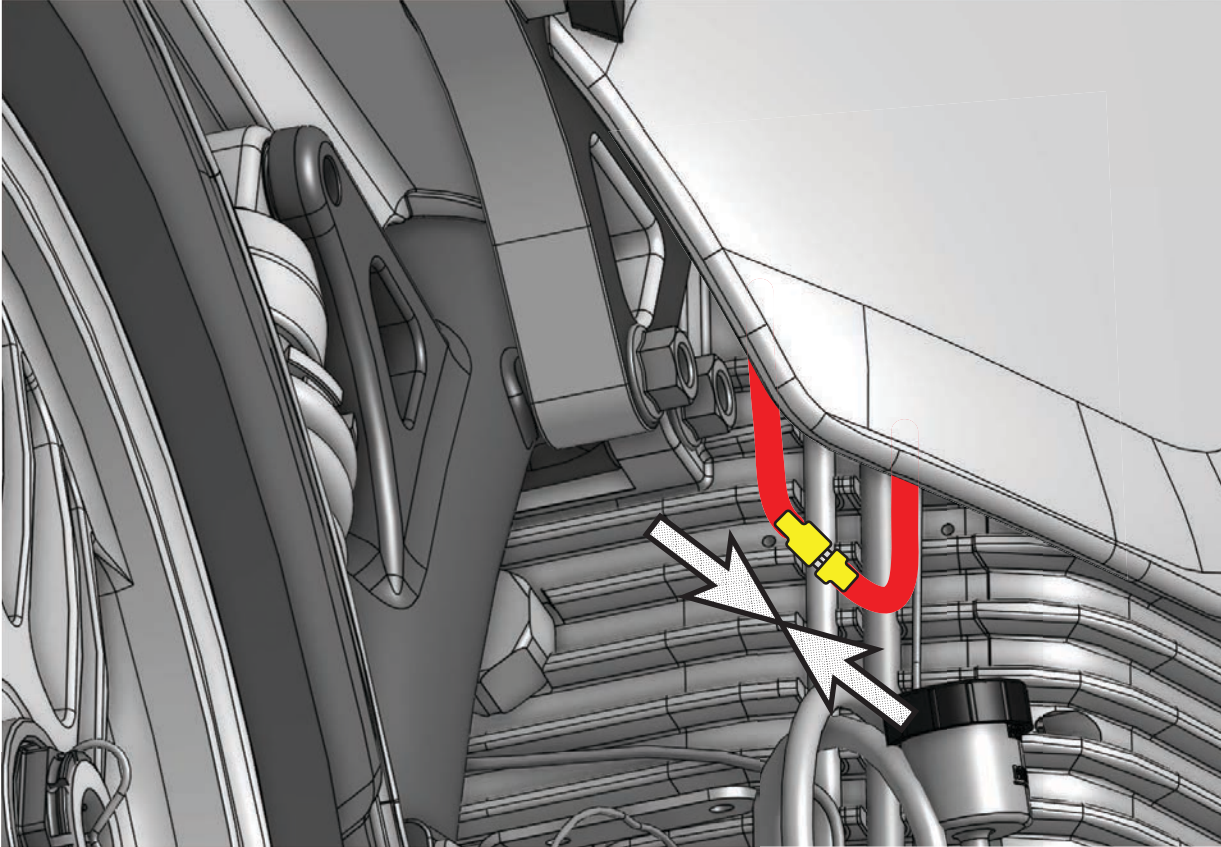

6. When you initially reboot and start up the bike, the bike UI may display incorrect figures while the monitoring system reboots and re-calibrates.